

RED SKY
SERIOUSLY SAFE LIGHTS™

CRANE MASTER SERIES

Technical Specification Sheet



PIONEERING INDUSTRIAL ILLUMINATION FOR HARSH & HAZARDOUS CONDITIONS

A leading manufacturer of premium LED lights for demanding work conditions

Headquartered in California, products assembled in the USA

Servicing global clients across 4 continents in metal processing, oil & gas, marine, manufacturing

Renowned for quality, dependability, client care and uncompromising safety standards

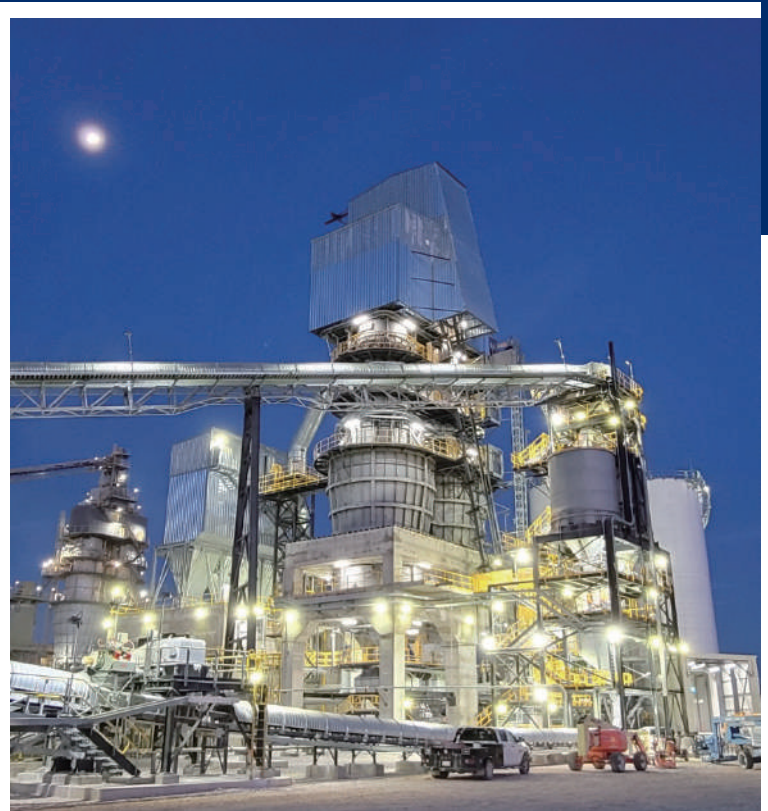

WHY CHOOSE RED SKY

❧ SERIOUSLY SAFE LIGHTS

- Rigorously tested in our professional labs
- Surpassing industry certifications and safety protocols
- Crafted with highest grade components for maximum durability

❧ TOP-NOTCH SERVICES

- Team of experts for seamless support
- Energy audit services, lighting simulation services
- Hassle-free return policy and management

❧ FAST DELIVERY

- Majority of orders delivered within 14 days
- Same day shipping for products in stock
- Real-time order tracking for full transparency



❧ SUSTAINABLE SOLUTIONS

- High luminous efficacy LEDs for energy savings
- Conscious product design
- Recyclable materials for products and packaging

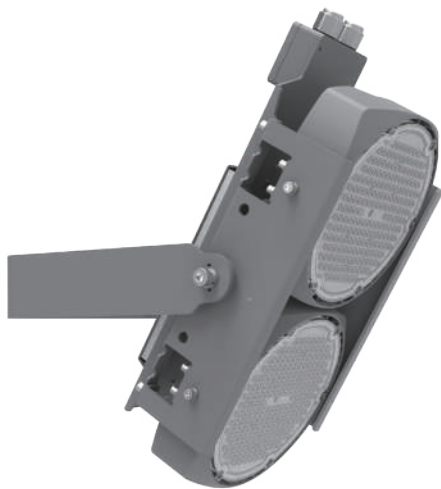

FEATURES



-  **5 Choices of Light Distributions**
30° / 60° / 90° / 120° / 30*120°
available for different applications from narrow to assymetric light distribution
-  **Easy and Through Wiring**
Built-in wiring compartment with two cable entries and WAGO 221 lever connectors for easy wiring (0.5~4mm²)
-  **The damper bracket is rotatable and ensures light is constantly targeted where required**

RATINGS

IP67
IK08

CERTIFICATIONS

CE EMC/LVD
UKCA
ROHS

TECHNICAL PARAMETERS

Specification	CMF-150	CMF-300	CMF-420	CMF-560
Electrical Parameters				
Power	150W	300W	420W	560W
Voltage/Frequency	100-240V AC 50/60Hz			
Power Factor	>90%			
THD	<20%			
L70	140,000 Hours@50°C			
Warranty	5 years			
Optical Parameters				
Lumen Output*	20,439Lm	42,425Lm	58,852Lm	79,230Lm
Lumen Efficacy*	140Lm/W			
Available Beam Angle	30°/60°/90°/30*120°(PC) 120°(Glass)			
Correlated Color Temperature (CCT)	4000K/5700K			
Color Rendering Index (CRI)	Ra>70			
Mechanical Parameters				
Finish	Polyster powder coating for uniform corrosion resistance			
Hardware	Stainless steel 316			
Lens Material	Clear Glass or Clear PC			
Mounting Options	Yoke			
Product Weight	16.5lbs/7.5kg	30.9lbs/14kg	39.7lbs/18kg	50.7lbs/23kg
Cable Entry	2 x M20			
Product Dimensions(LxWxH)	10.2x9.1x5.8 in (260x230x148 mm) 22x11x6.7 in (559x280x171 mm)		24.9x11x6.7 in (632x280x171 mm) 19.2x16.5x6.7 in (487x420x171 mm)	
Environmental Parameters				
Ambient Operating Temperature	-40°C~+55°C			
Optimal Operating Temperature	25°C			

* Value calculated based on 5700K and clear glass ,varies to different spec.

ORDERING INFORMATION

EXAMPLE: CMF-300-100-240-57K-HAR-90-CG-GRY-YKE

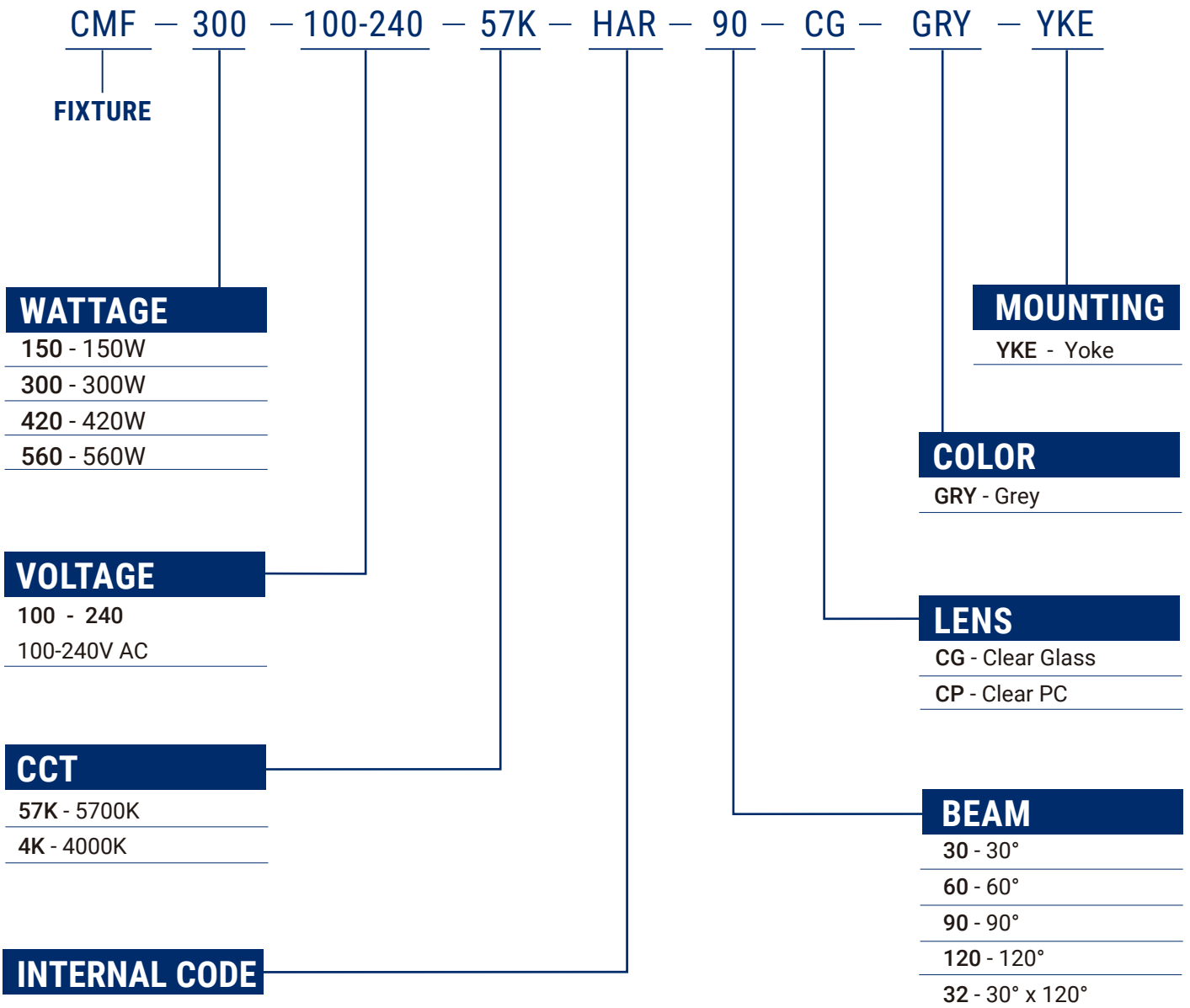

MOUNTING ACCESSORIES



Yoke
(SUS304)



Yoke with
Damper Bracket



SC05

Pard Number	Description	MPN Code
CMF-DPY	Crane Damper Bracket	309050274
SC05	Safety Cable Kit, CMF SERIES, SUS304	106060018

LUMEN TABLE

Part Number	Wattage (W)	CCT	Beam	Lens	Lumen Output (Lm)	Efficiency (Lm/W)
Voltage 100-240VAC						
CMF-150-100-240-57K-120-CG-GRY-YKE	150	5700K	120°	Clear Glass	20,439	146
CMF-150-100-240-57K-90-CP-GRY-YKE	150	5700K	90°	Clear PC	19,108	136
CMF-150-100-240-57K-60-CP-GRY-YKE	150	5700K	60°	Clear PC	19,410	138
CMF-150-100-240-57K-30-CP-GRY-YKE	150	5700K	30°	Clear PC	18,249	130
CMF-150-100-240-57K-32-CP-GRY-YKE	150	5700K	30°x120°	Clear PC	18,562	132
CMF-300-100-240-57K-120-CG-GRY-YKE	300	5700K	120°	Clear Glass	42,425	151
CMF-300-100-240-57K-90-CP-GRY-YKE	300	5700K	90°	Clear PC	40,071	142
CMF-300-100-240-57K-60-CP-GRY-YKE	300	5700K	60°	Clear PC	39,449	140
CMF-300-100-240-57K-30-CP-GRY-YKE	300	5700K	30°	Clear PC	36,491	129
CMF-300-100-240-57K-32-CP-GRY-YKE	300	5700K	30°x120°	Clear PC	40,574	144
CMF-420-100-240-57K-120-CG-GRY-YKE	420	5700K	120°	Clear Glass	58,852	143
CMF-420-100-240-57K-90-CP-GRY-YKE	420	5700K	90°	Clear PC	56,477	137
CMF-420-100-240-57K-60-CP-GRY-YKE	420	5700K	60°	Clear PC	54,459	132
CMF-420-100-240-57K-30-CP-GRY-YKE	420	5700K	30°	Clear PC	52,166	126
CMF-420-100-240-57K-32-CP-GRY-YKE	420	5700K	30°x120°	Clear PC	55,377	134
CMF-560-100-240-57K-120-CG-GRY-YKE	560	5700K	120°	Clear Glass	79,230	145
CMF-560-100-240-57K-90-CP-GRY-YKE	560	5700K	90°	Clear PC	75,361	137
CMF-560-100-240-57K-60-CP-GRY-YKE	560	5700K	60°	Clear PC	73,028	133
CMF-560-100-240-57K-30-CP-GRY-YKE	560	5700K	30°	Clear PC	69,638	127
CMF-560-100-240-57K-32-CP-GRY-YKE	560	5700K	30°x120°	Clear PC	72,627	132

For additional information, please contact your sales representative.

PHOTOMETRIC

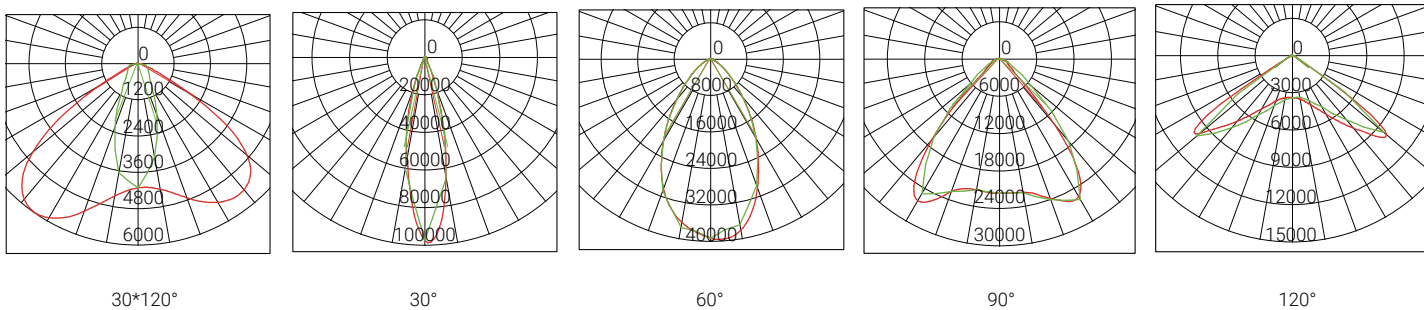

DIMENSIONS

unit: in(mm)

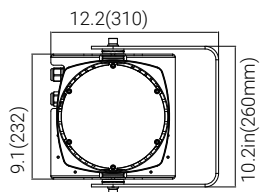

150W

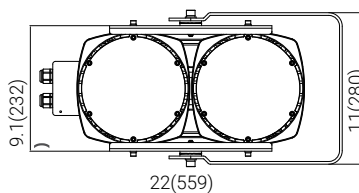

300W

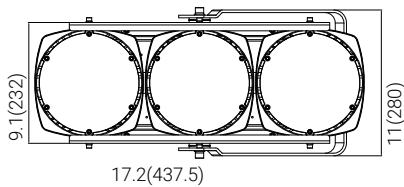
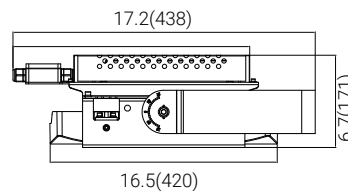
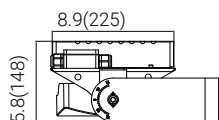

420W

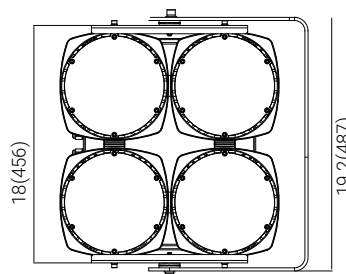

560W

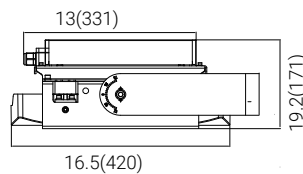
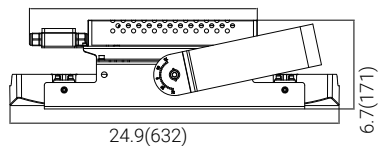

YOKE

DIMENSIONS

unit: in(mm)

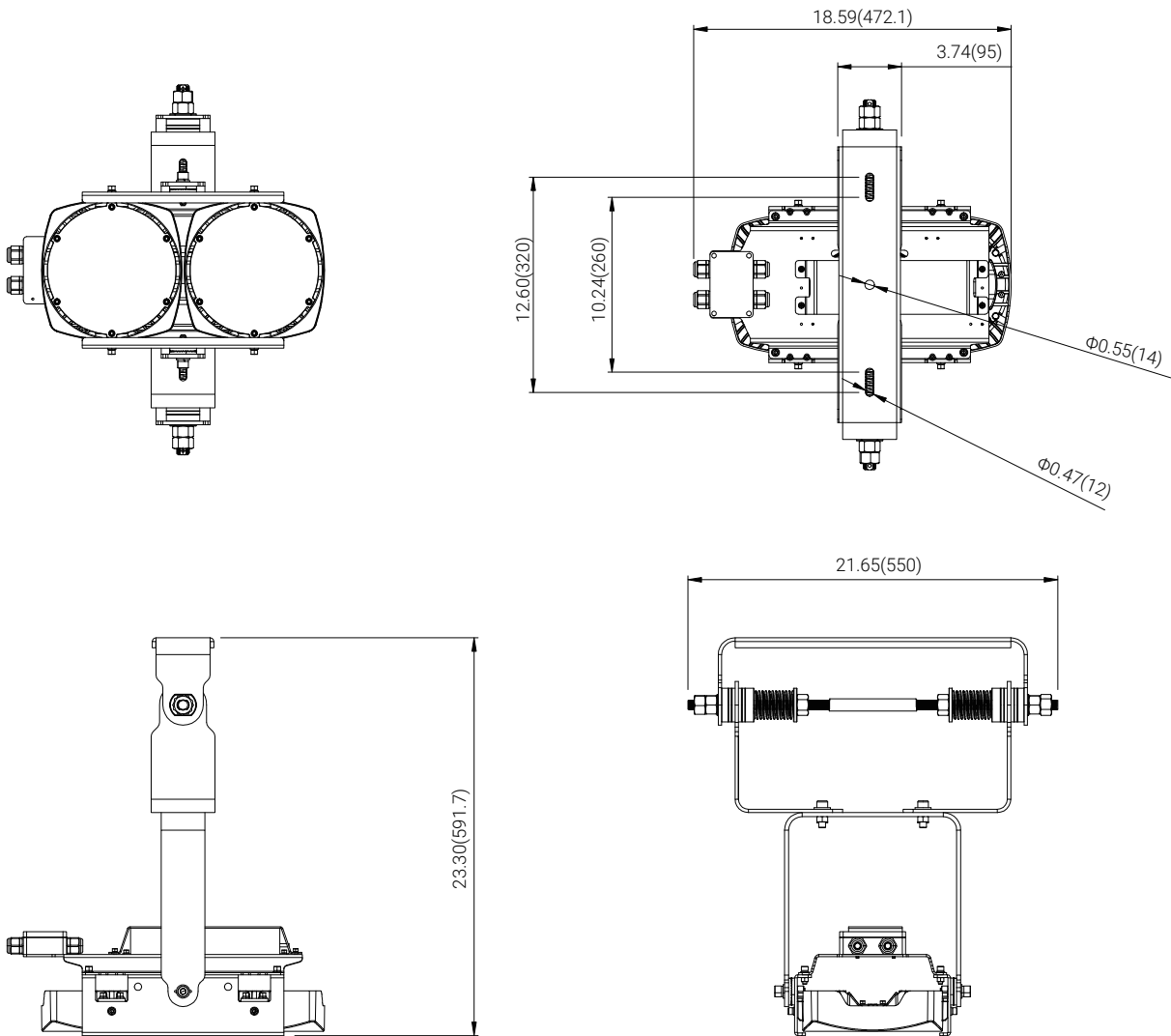

YOKE with Damper Bracket

HAZARDOUS LOCATION LIGHTING BASICS

Atmosphere Groups

Temperature Classification

Substance	Hazard Class	Division Groups	Zone Groups	Max. Surface Temperatures	NEC® 500 CEC®	NEC® 500/IEC-Group II
Acetylene	Class I Flammable Gases	Group A	IIC	450(842)	T1	T1
Hydrogen		Group B	IIC	300(572)	T2	
Ethylene		Group C	IIB	280(536)	T2A	T2
Propane		Group D	IIA	260(500)	T2B	
Methane		Group D	IIA ²	230(446)	T2C	
Combustible Metal Dusts	Class II Combustible Dusts	Group E ¹	IIIC ³	215(419)	T2D	T3
Combustible Carbonaceous Dust		Group F	IIIB ³	200(392)	T3	
Combustible Dusts not in Group E or F (Flour, Grain, Wood, Plastics, Chemicals)		Group G	IIIB ³	180(256)	T3A	
Combustible Fibers and Flyings		Class III Fibers and Flyings	Not Applicable	IIIA ³	165(329)	
				160(320)	T3C	
				135(275)	T4	T4
				120(248)	T4A	
				100(212)	T5	T5
				85(185)	T6	T6

Note 1: Group E is applicable to Class II, Division 1 only.
 Note 2: Methane is a Group IIA Gas for non-mining applications.
 Note 3: Group IIIA, IIIB and IIIC have not been adopted by the Canadian Electrical Code.

Classification of Divisions and Zones

Hazard Level	Division Scheme	Zone Scheme	Definitions
Continuous Hazard	Division 1	Zone 0 / Zone 20	A place in which an explosive atmosphere is continually present
Intermittent Hazard		Zone 1 / Zone 21	A place in which an explosive atmosphere is likely to occur in normal operation
Hazard Under Abnormal Conditions	Division 2	Zone 2 / Zone 22	A place in which an explosive atmosphere is not likely to occur in normal operation, but may occur for short periods

IP Codes

1st No.	Solid Objects
0	No protection
1	Objects greater than 50mm
2	Objects greater than 12.5mm
3	Objects greater than 2.5mm
4	Objects greater than 1mm
5	Dust protected
6	Dust proof
2nd No.	Liquids
0	No protection
1	Vertically dripping
2	Dripping up to 15°
3	Limited spraying
4	Splashing from all directions
5	Hosing jets from all directions
6	Strong hosing jets from all directions
7	Temporary immersion
8	Continuous immersion
9	Steam-jet cleaning

IK Ratings

IK Code	Level of Protection Achieved
IK00	Not protected
IK01	Protected against 0.14 joules impact
IK02	Protected against 0.2 joules impact
IK03	Protected against 0.35 joules impact
IK04	Protected against 0.5 joules impact
IK05	Protected against 0.7 joules impact
IK06	Protected against 1 joules impact
IK07	Protected against 2 joules impact
IK08	Protected against 5 joules impact
IK09	Protected against 10 joules impact
IK10	Protected against 20 joules impact

RED SKY

SERIOUSLY SAFE LIGHTS™

AUTHORISED DISTRIBUTOR

daly

Middle East

Partner under the UK, Qatar and Oman

Daly Middle East L.L.C.



+971 4 887 2049
+971 4 887 8184
sales@daly-me.com

Plot 597-952, WH #3, Kamala Trading Compound,
Dubai Investment Park 2, PO Box 282131, Dubai,
U.A.E.

DME Trading and Maintenance WLL.



+974 5023 1614
Vipin Venugopalan
sales@daly-me.com

Al Shoumoukh Towers, Office 1041, Tower B, Floor
10, C-Ring Road, Al Sadd, PO Box 55896, Doha,
Qatar

Bin Moosa Trading and Contracting LLC.



+968 2 411 1807
+968 2 411 1889
+968 7952 7504

Mohammed Hanif | PO Box 1118, PC 1111,
Muscat, Sultanate of Oman
sales@daly-me.com

DME Trading and Maintenance Limited



sales@daly-me.com
Point, 19 Oxford Road, Bournemouth,
Dorset, United Kingdom, BH8 8GS

Daly Middle East DWC LLC

Building A3, Floor 1, Office 140, DWC, Dubai P.O. Box 712521



+971 4 887 2049



sales@daly-me.com



www.daly-me.com



@daly-middle-east