

RED SKY
SERIOUSLY SAFE LIGHTS™

BLOCK SERIES C1

Technical Specification Sheet



PIONEERING INDUSTRIAL ILLUMINATION FOR HARSH & HAZARDOUS CONDITIONS

A leading manufacturer of premium LED lights for demanding work conditions

Headquartered in California, products assembled in the USA

Servicing global clients across 4 continents in metal processing, oil & gas, marine, manufacturing

Renowned for quality, dependability, client care and uncompromising safety standards

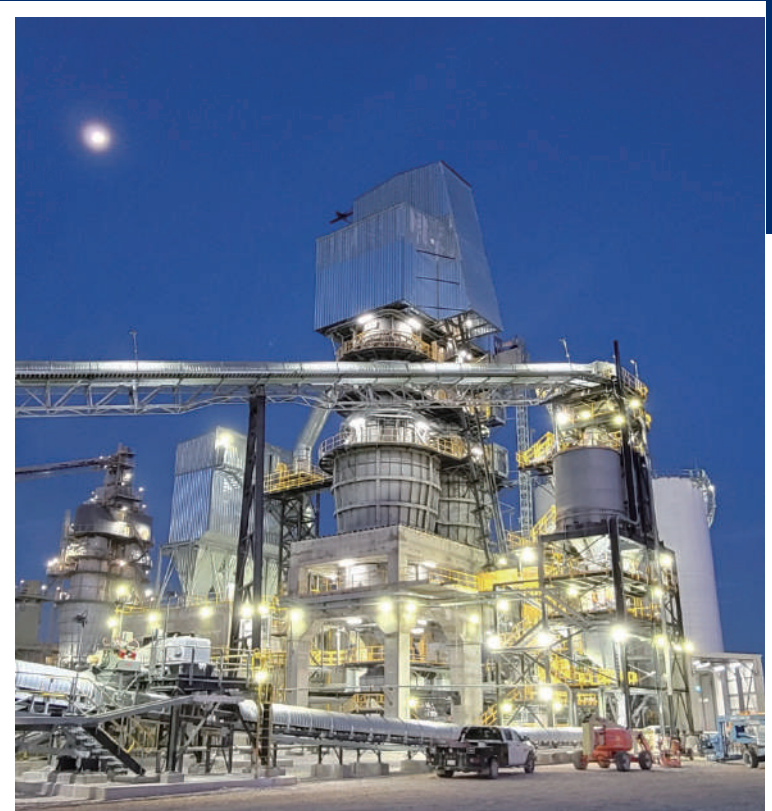

WHY CHOOSE RED SKY

❧ SERIOUSLY SAFE LIGHTS

- Rigorously tested in our professional labs
- Surpassing industry certifications and safety protocols
- Crafted with highest grade components for maximum durability

❧ TOP-NOTCH SERVICES

- Team of experts for seamless support
- Energy audit services, lighting simulation services
- Hassle-free return policy and management

❧ FAST DELIVERY

- Majority of orders delivered within 14 days
- Same day shipping for products in stock
- Real-time order tracking for full transparency

❧ SUSTAINABLE SOLUTIONS

- High luminous efficacy LEDs for energy savings
- Conscious product design
- Recyclable materials for products and packaging



BLOCK SERIES

FEATURES

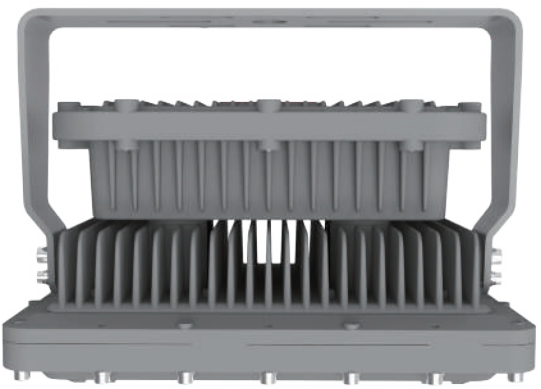

Excellent Heat Dissipation

Self-contained LED and Driver compartment with external air-flow fins provide exceptional heat dissipation to ensure long lifespan

Easy and Through Wiring

Built-in wiring compartment with two NPT 3/4" entries and WAGO 221 lever connectors for easy wiring (UL/CSA 20-10AWG)

RATINGS

Zone 1&2
Zone 21&22

CERTIFICATIONS

IECEX
Ex db IIB T6 Gb
Ex tb IIIC T85°C Db
-25°C ≤ Ta ≤ +50°C

TECHNICAL PARAMETERS

Specification	BLK-C1-80	BLK-C1-100	BLK-C1-150
Electrical Parameters			
Power	80W	100W	150W
Voltage/Frequency	100-240V AC, 50/60Hz		
Power Factor	>90%		
THD	<20%		
L70	140,000 Hours@50°C		
Surge Protection	4KV		
Warranty	LEDs: 10 years, Driver: 5 years		
Optical Parameters			
Lumen Output*	10,288Lm	12,274Lm	18,646Lm
Lumen Efficacy*	130Lm/W		
Available Beam Angle	120°		
Correlated Color Temperature (CCT)	4000K/5700K		
Color Rendering Index (CRI)	Ra>70		
Mechanical Parameters			
Finish	Thermoset Powdercoat		
Hardware	Stainless steel 316		
Lens Material	Clear Glass		
Mounting Options	Yoke, Stanchion		
Product Weight	33.5lbs/15.2kg	33.7lbs/15.3kg	34.2lbs/15.5kg
Cable Entry	(2) 3/4" NPT		
Product Dimensions(L×W×H)	12.9×10.7×6.9in (328×271×176mm)		
Environmental Parameters			
Ambient Operating Temperature	-25°C ~ +50°C		
T-Code Rating	Gas – T6, Dust – 85°C		

* value calculated based on 5700K and clear glass ,varies to different spec.

ORDERING INFORMATION

EXAMPLE: BLK-80-100-240-57K-HAR-120-C1-CG-GRY-YKE

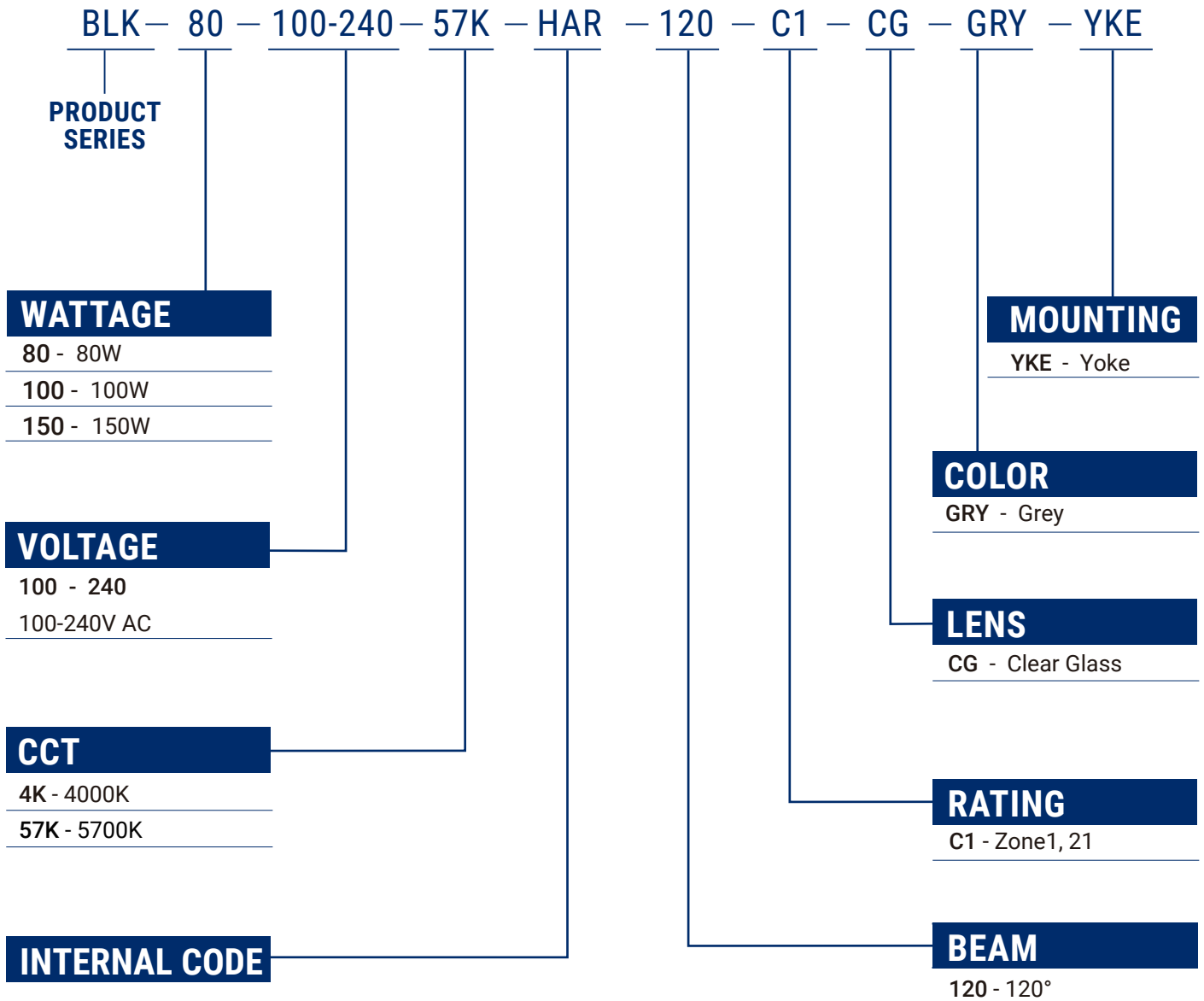

MOUNTING ACCESSORIES

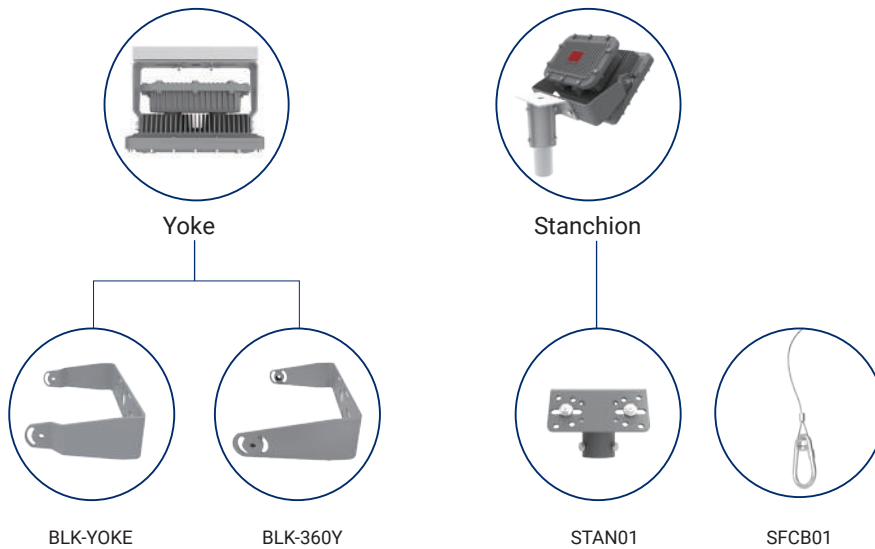

Mounting Method	PN	Description	MPN Code
Yoke	BLK-YOKE	Yoke Mount BLK SERIES, SS304. Power Coated Grey RAL7037	309050055
	BLK-360Y	360° rotation Yoke Mount. BLK SERIES. SS304. Power Coated Grey RAL7037	201010115
Stanchion	STAN01*	Slip-Fit Stanchion Mount Kit. BLK SERIES. SS304. Power Coated Grey RAL7037	309050300
	SFCB01	Safety Cable Kit, BLK & RDX SERIES, SS304	106060018

* Requires A Yoke Mount

LUMEN TABLE

Part Number	Wattage (W)	CCT	Beam	Lens	Lumen Output (Lm)	Efficiency (Lm/W)
Voltage 100-240V AC						
BLK-80-100-240-57K-120-C1-CG-GRY-YKE	80	5700K	120°	Clear Glass	10,288	124
BLK-100-100-240-57K-120-C1-CG-GRY-YKE	100	5700K	120°	Clear Glass	12,274	124
BLK-150-100-240-57K-120-C1-CG-GRY-YKE	150	5700K	120°	Clear Glass	18,646	122

For additional information, please contact your sales representative.

PHOTOMETRIC

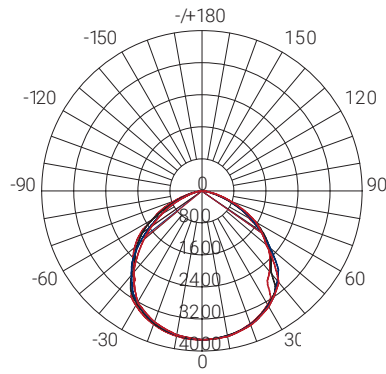

120°

DIMENSIONS

unit: in(mm)

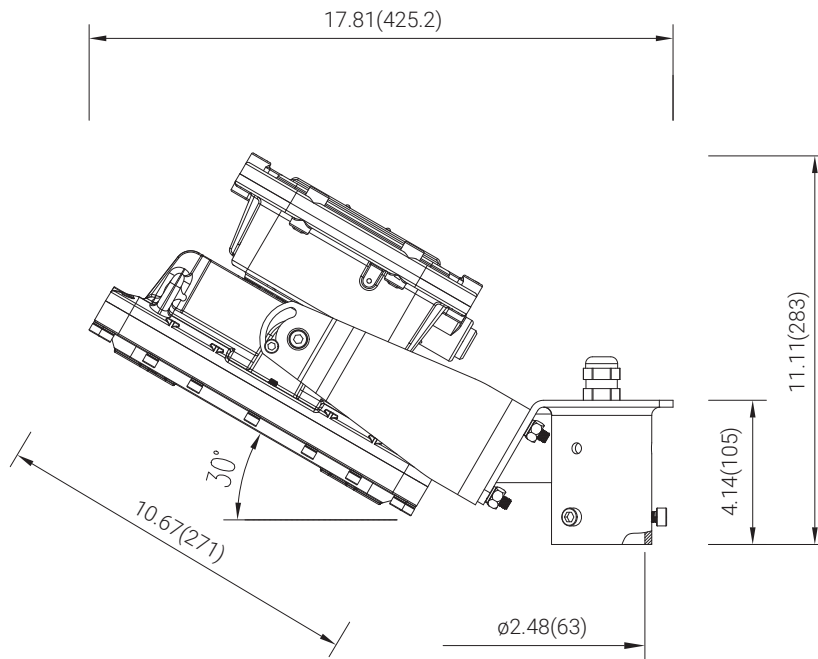

Stanchion

DIMENSIONS

unit: in(mm)

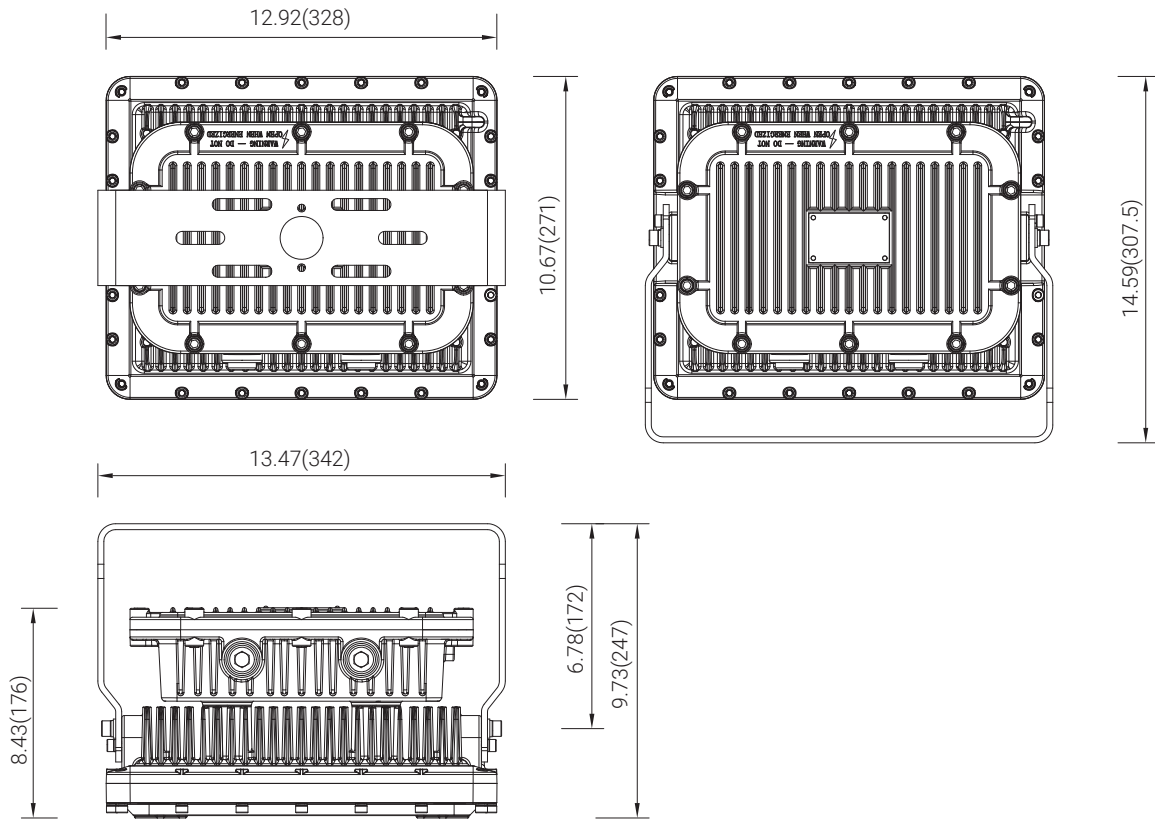

Yoke

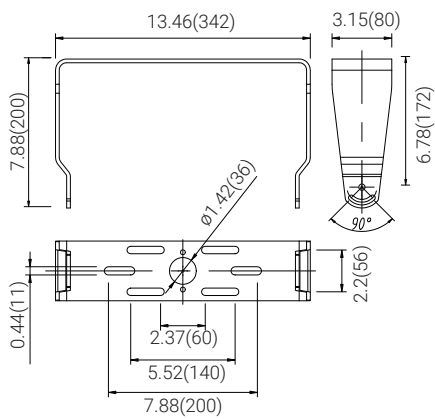

BLK-YOKE

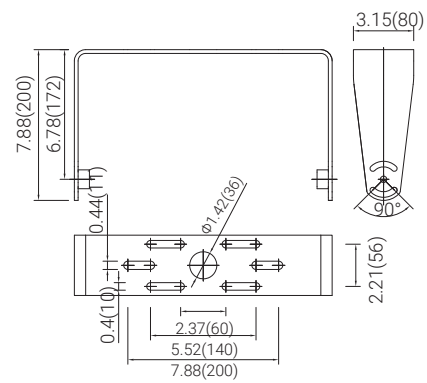

YOKE-360Y

HAZARDOUS LOCATION LIGHTING BASICS

Atmosphere Groups

Temperature Classification

Substance	Hazard Class	Division Groups	Zone Groups	Max. Surface Temperatures	NEC® 500 CEC®	NEC® 500/IEC-Group II
Acetylene	Class I Flammable Gases	Group A	IIC	450(842)	T1	T1
Hydrogen		Group B	IIC	300(572)	T2	
Ethylene		Group C	IIB	280(536)	T2A	T2
Propane		Group D	IIA	260(500)	T2B	
Methane		Group D	IIA ²	230(446)	T2C	
Combustible Metal Dusts	Class II Combustible Dusts	Group E ¹	IIIC ³	215(419)	T2D	T3
Combustible Carbonaceous Dust		Group F	IIIB ³	200(392)	T3	
Combustible Dusts not in Group E or F (Flour, Grain, Wood, Plastics, Chemicals)		Group G	IIIB ³	180(256)	T3A	
Combustible Fibers and Flyings		Class III Fibers and Flyings	Not Applicable	IIIA ³	165(329)	
				160(320)	T3C	
				135(275)	T4	T4
				120(248)	T4A	
				100(212)	T5	T5
				85(185)	T6	T6

Note 1: Group E is applicable to Class II, Division 1 only.
 Note 2: Methane is a Group IIA Gas for non-mining applications.
 Note 3: Group IIIA, IIIB and IIIC have not been adopted by the Canadian Electrical Code.

Classification of Divisions and Zones

Hazard Level	Division Scheme	Zone Scheme	Definitions
Continuous Hazard	Division 1	Zone 0 / Zone 20	A place in which an explosive atmosphere is continually present
Intermittent Hazard		Zone 1 / Zone 21	A place in which an explosive atmosphere is likely to occur in normal operation
Hazard Under Abnormal Conditions	Division 2	Zone 2 / Zone 22	A place in which an explosive atmosphere is not likely to occur in normal operation, but may occur for short periods

IP Codes

1st No.	Solid Objects
0	No protection
1	Objects greater than 50mm
2	Objects greater than 12.5mm
3	Objects greater than 2.5mm
4	Objects greater than 1mm
5	Dust protected
6	Dust proof
2nd No.	Liquids
0	No protection
1	Vertically dripping
2	Dripping up to 15°
3	Limited spraying
4	Splashing from all directions
5	Hosing jets from all directions
6	Strong hosing jets from all directions
7	Temporary immersion
8	Continuous immersion
9	Steam-jet cleaning

IK Ratings

IK Code	Level of Protection Achieved
IK00	Not protected
IK01	Protected against 0.14 joules impact
IK02	Protected against 0.2 joules impact
IK03	Protected against 0.35 joules impact
IK04	Protected against 0.5 joules impact
IK05	Protected against 0.7 joules impact
IK06	Protected against 1 joules impact
IK07	Protected against 2 joules impact
IK08	Protected against 5 joules impact
IK09	Protected against 10 joules impact
IK10	Protected against 20 joules impact

RED SKY

SERIOUSLY SAFE LIGHTS™

AUTHORISED DISTRIBUTOR

daly

Middle East

Partner under the UK, Qatar and Oman

Daly Middle East L.L.C.



+971 4 887 2049
+971 4 887 8184
sales@daly-me.com

Plot 597-952, WH #3, Kamala Trading Compound,
Dubai Investment Park 2, PO Box 282131, Dubai,
U.A.E.

DME Trading and Maintenance WLL.



+974 5023 1614
Vipin Venugopalan
sales@daly-me.com

Al Shoumoukh Towers, Office 1041, Tower B, Floor
10, C-Ring Road, Al Sadd, PO Box 55896, Doha,
Qatar

Bin Moosa Trading and Contracting LLC.



+968 2 411 1807
+968 2 411 1889
+968 7952 7504

Mohammed Hanif | PO Box 1118, PC 1111,
Muscat, Sultanate of Oman
sales@daly-me.com

DME Trading and Maintenance Limited



sales@daly-me.com
Point, 19 Oxford Road, Bournemouth,
Dorset, United Kingdom, BH8 8GS

Daly Middle East DWC LLC

Building A3, Floor 1, Office 140, DWC, Dubai P.O. Box 712521



+971 4 887 2049



sales@daly-me.com



www.daly-me.com



@daly-middle-east